

?

4 2009

Kenji Kuno (Kuno.Kenji@jica.go.jp)

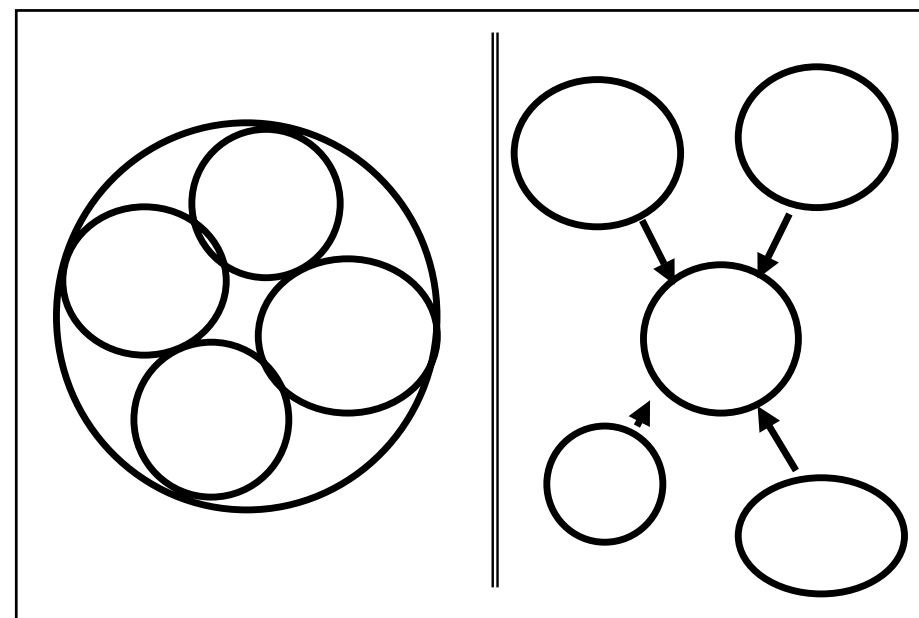

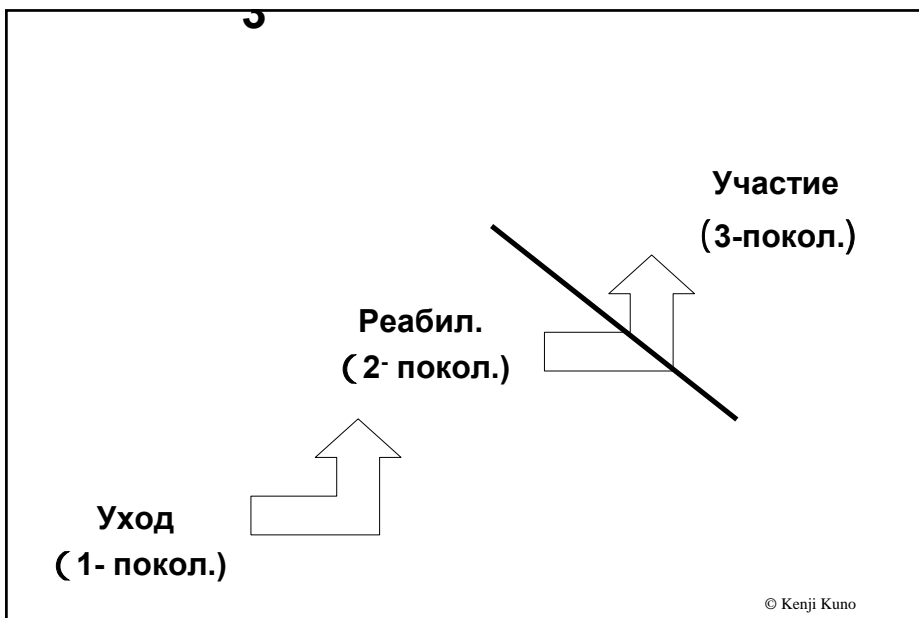
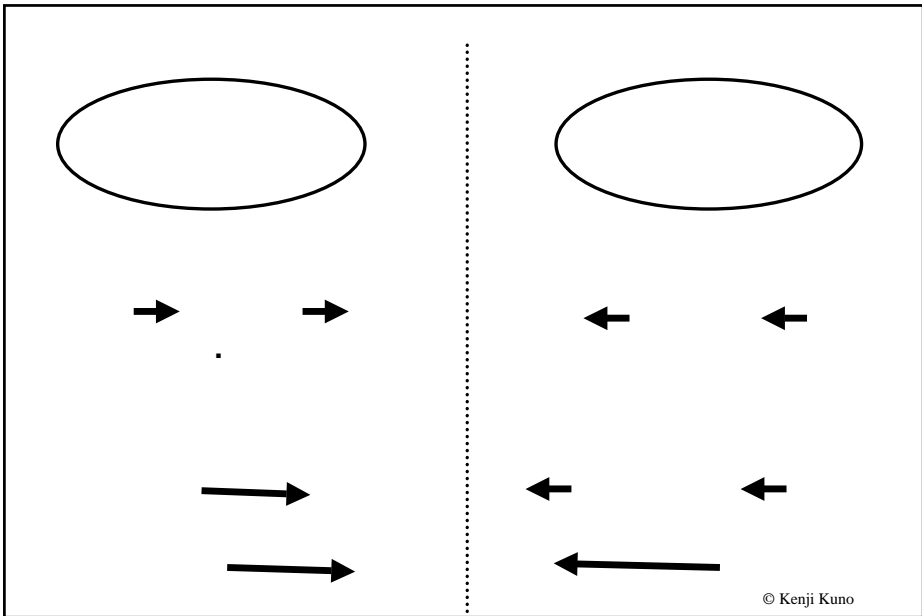
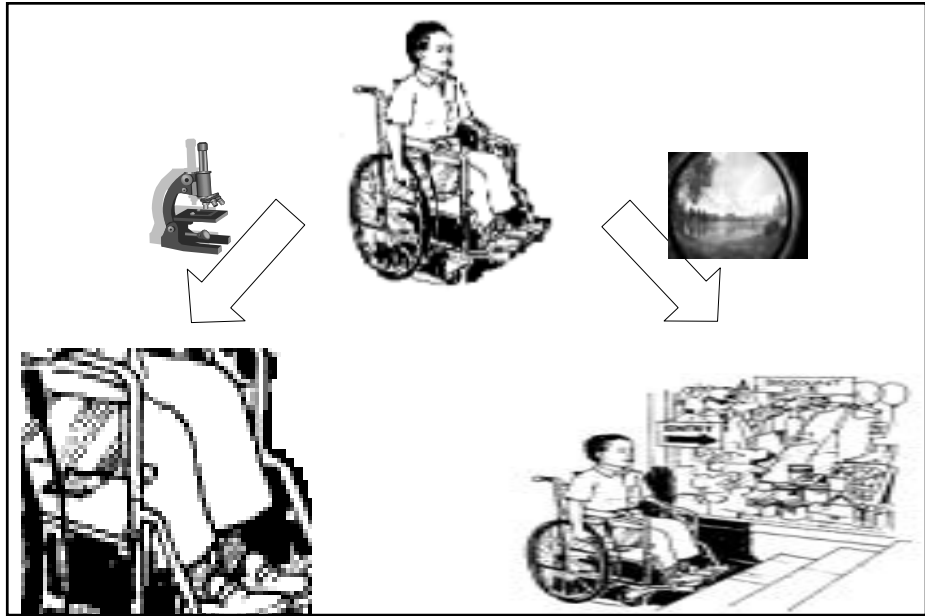
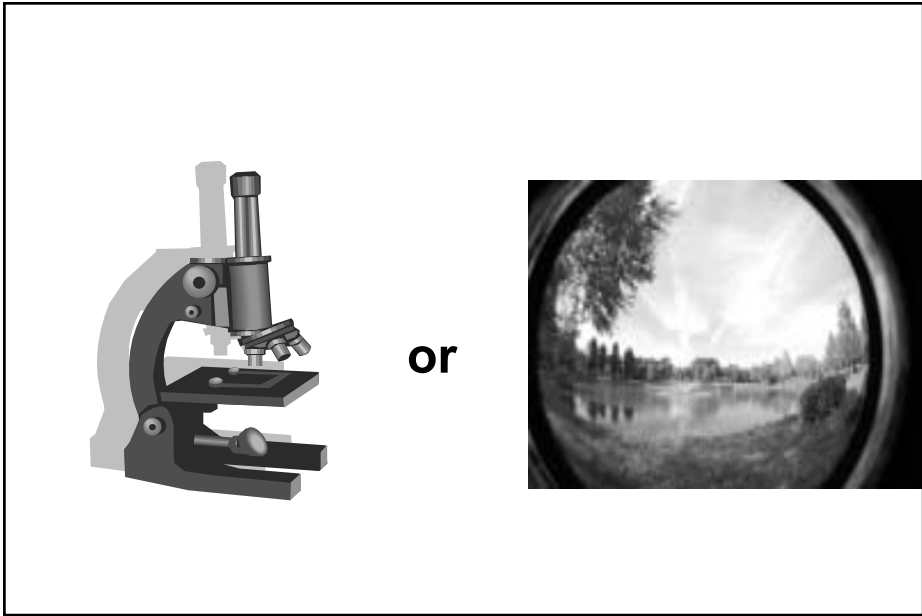

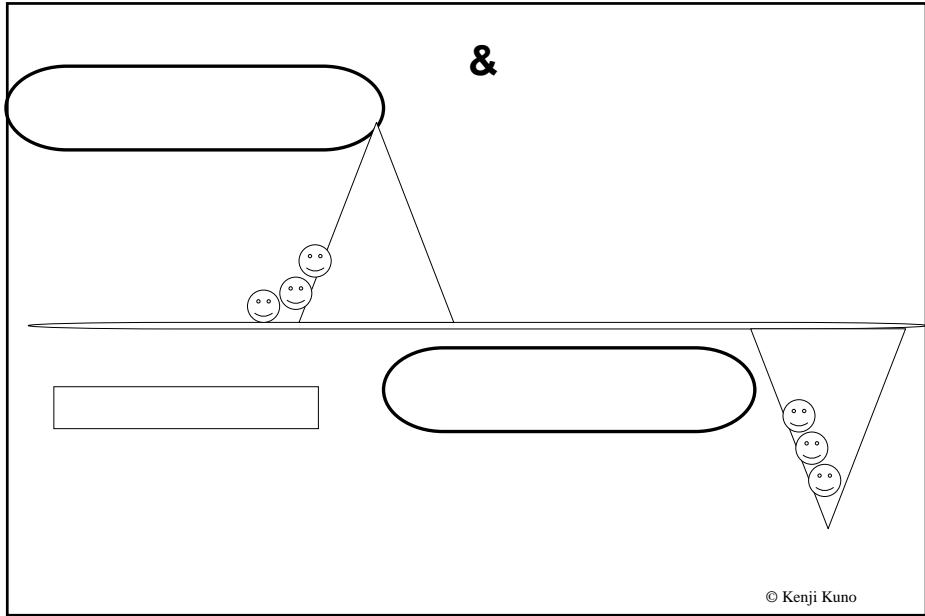
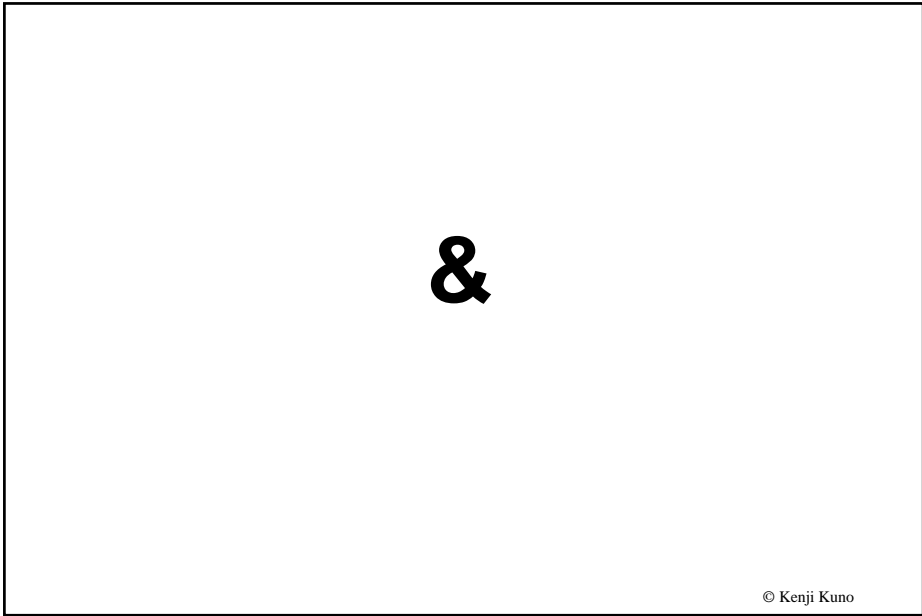
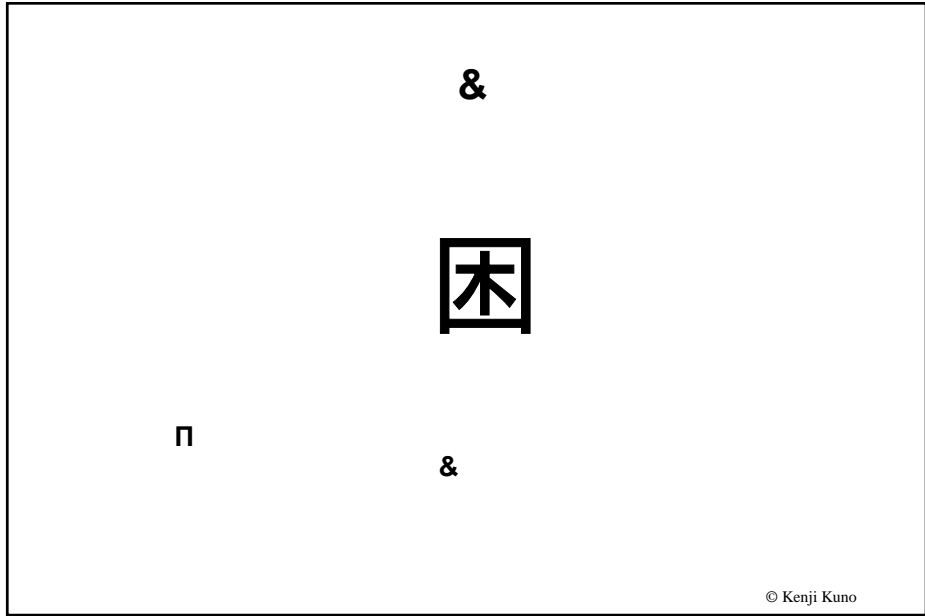
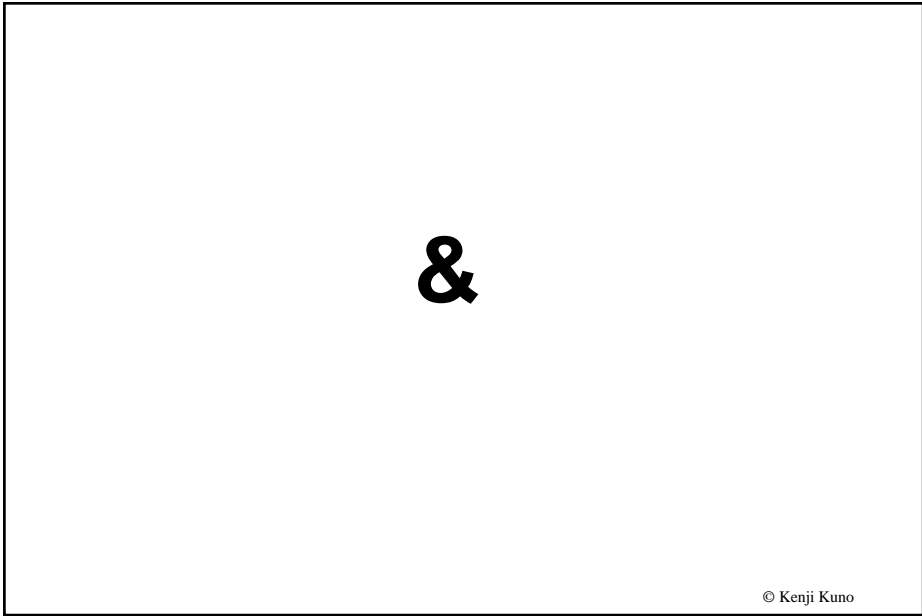

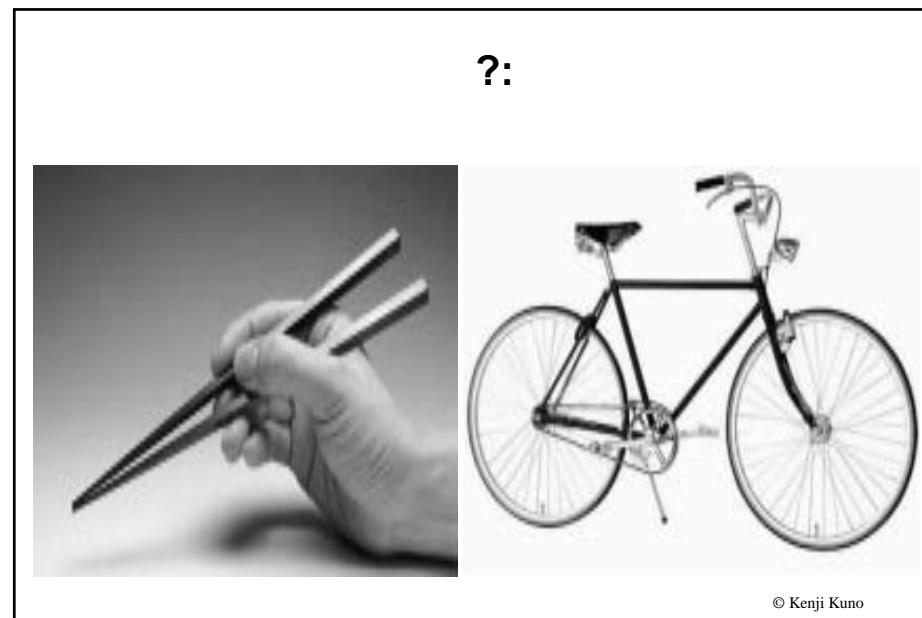
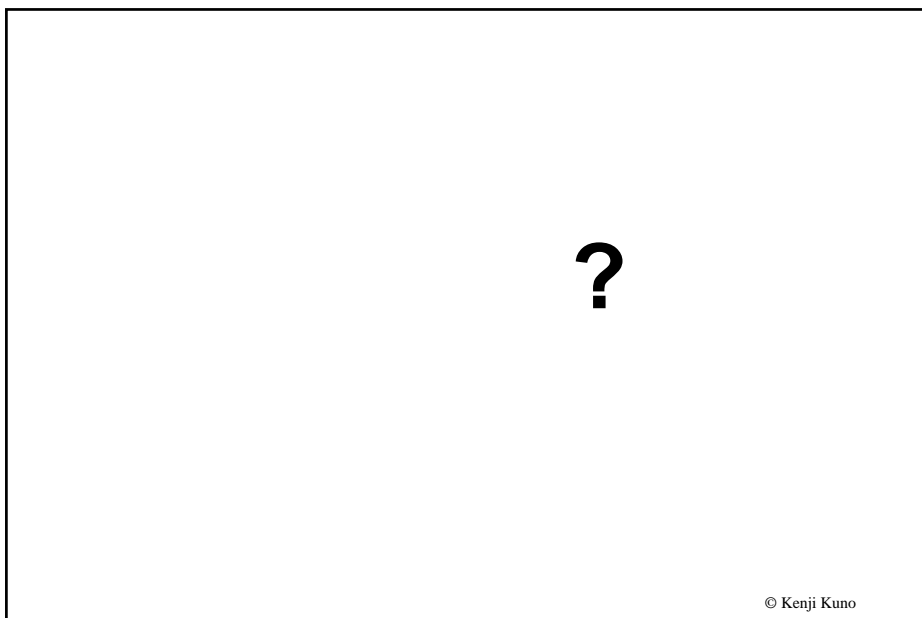
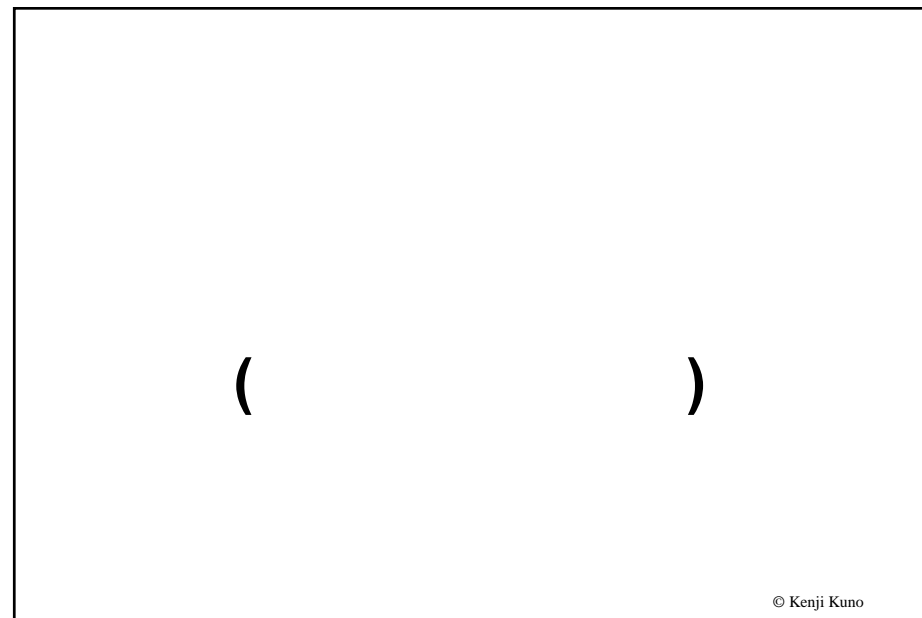
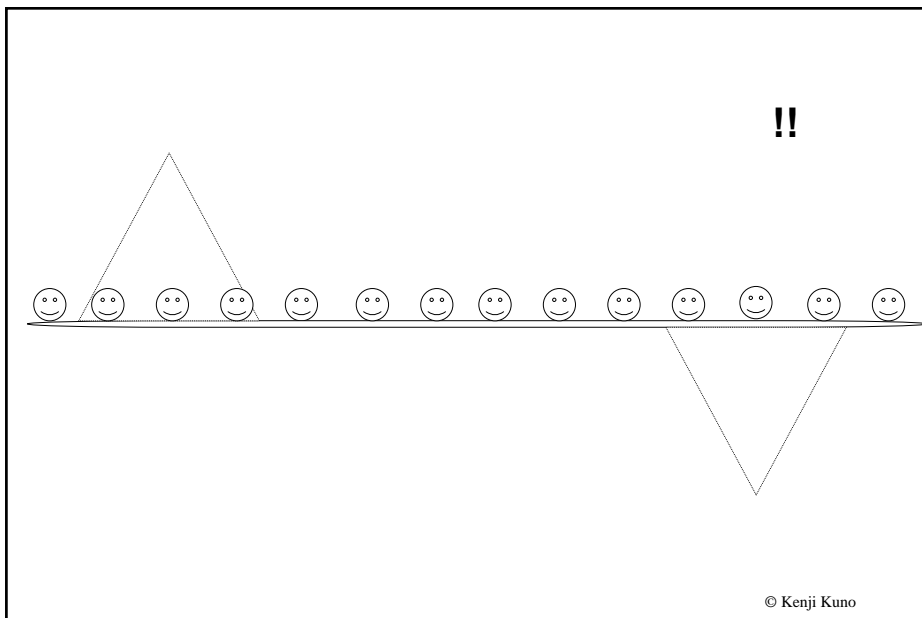

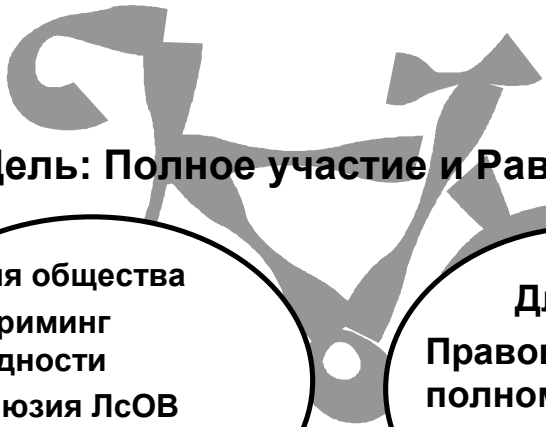

Цель: Полное участие и Равенство

Для общества
Мейнстриминг
инвалидности
Инклюзия ЛсОВ
Предос.чрезв. полномоч.

Для ЛсОВ
Правовые
полномочия ЛсОВ

© Kenji Kuno

? :

/

&

()

DET :

()

© Kenji Kuno

© Kenji Kuno

?

© Kenji Kuno

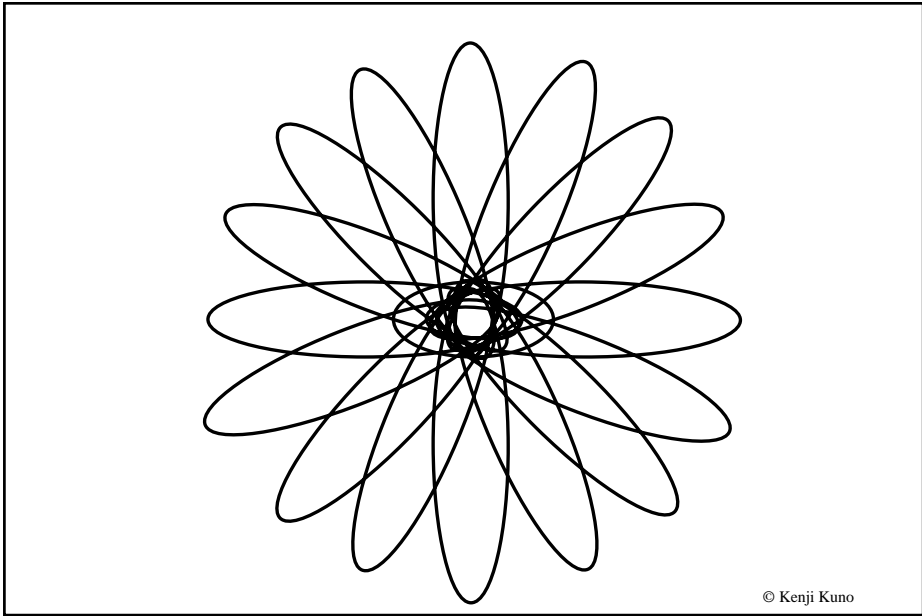

© Kenji Kuno

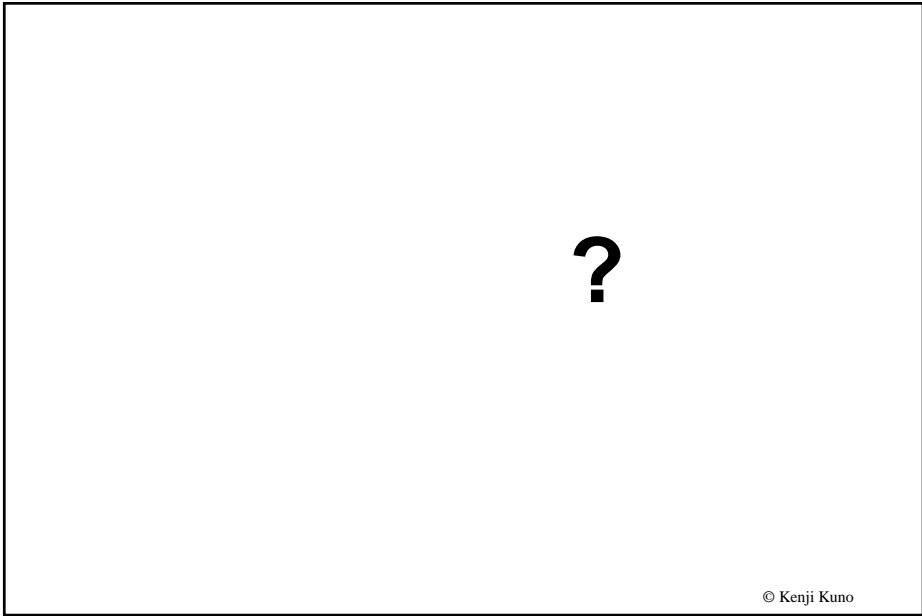

© Kenji Kuno

Как?

Инклюзия

- Устранить барьеры
- Заполнить пробелы
- Политика и сервис
- Макро и микро Общество

Правовые полномочия

- Способность
- Принятие решения
- Критическое сознание (Общество можно изменить)

ЛсОВ

© Kenji Kuno

/BMF

/CRPD

© Kenji Kuno

:

(2015 .)

- 1.
- 2.
- 3.
- 4.
- 5.

© Kenji Kuno

/B

MF

,

-

2 - Декада лиц с ограниченными возможностями в

-

(2003 г.-2012 г.)

/BMF

-

© Kenji Kuno



/DAD:

/RHA

© Kenji Kuno

() ,
 ()

© Kenji Kuno

USAID, NORAD, JICA, SIDA, DANIDA

-
- () : **WPA & SR**
-
- , (.)
- ,

© Kenji Kuno

(/DAD)
 ()

-
-
-
- (, :
- ())
-

© Kenji Kuno



